

VW2005 MPEG-1, -2, -4 Audio/Video Encoder Chip

Product Brief

The VW2005 is a real-time MPEG-1, -2 and -4 audio/video encoder chip that fully complies with ISO/IEC-11172-2, ISO/IEC-13818-2, ISO/IEC-14496-2 and ITU-T H.263. The VW2005 accepts uncompressed ITU-R.BT-656 video and I2S audio, compresses the video into MPEG-1, -2, -4 or H.263 formats, compresses the audio into MPEG-1, MPEG-2, MP3, AAC or AC-3 audio formats, and outputs them as transport streams for network applications or program streams for storage applications.



Feature List

Video Encoding

- Support for MPEG-1
- Support for MPEG-2 MP@ML
- Support for MPEG-4 Simple Profile @ L1, L2 and L3, with extensions to full D1 and interlaced video
- Adaptive field/frame motion compensation and DCT type
- 4:2:2 to 4:2:0 conversion
- Scene change detection
- Inverse telecine (3:2 pulldown)
- Motion estimation search range +/-127 pels horizontal and +/-63 pels vertical, with half-pel accuracy
- 8-tap horiz. filter and 4-tap vert. filter
- Extraction of VBI data (including close captioned and NABTS data) from the ITU-R.BT-656 input

- Support for private and user data insertions from VBI or host/PCI port
- Dynamically adjustable controls
- • Fixed frame rates of 29.97 (NTSC) or 25 (PAL) frames per second, or variable frame rates in low delay mode
- • Constant or variable bit-rate from 22.5 Kb/s to 15 Mb/s
- • Horizontal resolution between 128 and 720 pixels in 16-pixel steps
- • Vertical resolution between 80 and 480 pixels (NTSC) or 576 pixels (PAL) in 16-pixel steps
- Programmed GOP structure and length: I, IP, IBP and IBBP
- Programmed low delay mode

Audio Encoding

- MPEG-1 Layer I, II and III (MP3)
- MPEG-2 Layer I and II
- 2-channel down-mixed AAC
- 2-channel down-mixed AC-3
- Sampling frequencies: 8, 16, 22.05, 24, 32, 44.1, 48 and 96 KHz.
- Bits per channel: 16, 20, 24, 32

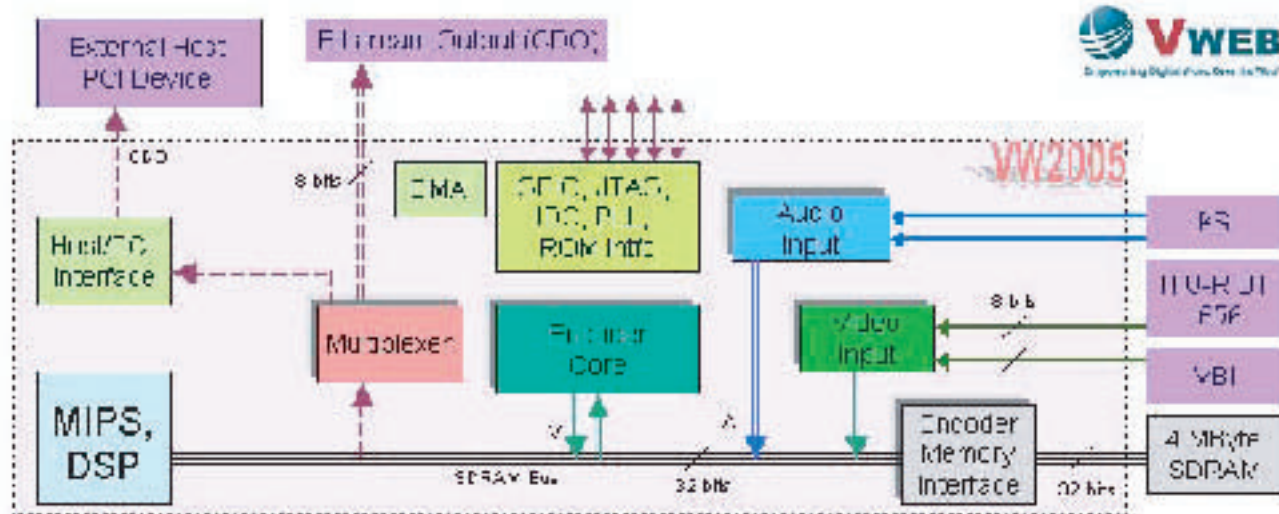

VW2005 MPEG-1, -2, -4 Audio/Video Encoder Chip

Multiplexing

Input

- User data or VBI data insertion
- Video and audio PES or ES

Output

- MPEG-1 System Stream
- MPEG-2 PS or TS
- MPEG-4 embedded in MPEG-2 TS
- PES and ES output

Interfaces

Host Interfaces

- 8- or 16-bit Motorola-style interface, or
- 16-bit Intel-style interface, or
- PCI interface: 32 bits, 33 MHz.

System Interfaces

- GPIO (general purpose input/output): 12 pins
- IDC (inter-device communications, similar to Philips I2C)
- SDRAM
- 32-bit memory interface, using 1Mx16-5 or 2Mx32-5 SDRAM
- Minimum SDRAM requirement: 4 MB

A/V Input Interfaces

Uncompressed Input

- Video: 8-bit ITU-R.BT-656
- Audio: I2S (2 each)
- VBI, user data: 8-bit video input

A/V Output Interfaces

Compressed Output

- 8-bit / 1-bit compressed data output interface (CDO)
- Host/PCI interface

General System Facts

- 162 MHz MIPS-like RISC processor with DSP extensions for multiplexing, demultiplexing, audio encoding and audio decoding
- 365-pin PBGA package; physical dimensions: 27 mm by 27mm
- Input voltages:
 - 1.8 V internal
 - 3.3 V I/O

- Estimated power consumption under 1.0 W in normal operating mode; on-chip power management
- Boundary scan and assembly testing compliant with IEEE 1149.1 (JTAG) and EPI EJTAG 2.0 (extended JTAG)

Applications

The VW2005 is ideally suited for the following consumer applications:

- Camcorders and network cameras
- Personal video recorder
- Set-top boxes
- PC capture devices for video capture, content creation, and display
- VCD, Super-VCD and DVD player and recorder
- Cellular phones and PDAs

In addition, the VW2005 is suited for the following network applications:

- Streaming video distribution over DSL, cable, ethernet, fiber and wireless networks
- Video conferencing
- Security / surveillance
- Video-on-demand servers

Features and Benefits

Saves money and power

- Uses less than 8 MB of external SDRAM
- Uses 32-bit SDRAM interface
- Proprietary motion estimation algorithm

Decreases time to market

- Easy to setup and configure

Superior video quality

- The rate control algorithm monitors 60 different variables, which results in a more consistent GOP structure; thus, scene changes are handled well.

Superior flexibility

- Dynamically programmable frame rates, bit rates, resolution and low delay mode
- Programmable GOP structure

Superior ingenuity

- MPEG-1, -2, -4 full-D1 interlaced encoder
- Low latency support
- MPEG-4 short header support (H.263 baseline support)